

MULTIPURPOSE 14 MeV NEUTRON SOURCE AT BRATISLAVA: DESIGN CONCEPT*

JURAJ PIVARČ**¹, STANISLAV HLAVÁČ**², JOZEF KRÁL**², PAVEL
OBLOZINSKY**², IGOR RIBANSKY**², IVAN TURZO**², Bratislava
HELMUTH HELFER***³, Dresden

The present state of design of the multipurpose intense 14 MeV neutron source based on a D⁺ ion beam and a metal tritide target is reported. It is essentially a 300 keV electrostatic air insulated accelerator capable to accelerate a deuterium ion beam up to 10 mA. With such a beam and a beam spot of 1 cm², a neutron yield typically 10¹² n/s and a useful target lifetime of around 10 h are expected. Various users requirements are met by means of three beam lines: an intense, low current dc and a low current fast pulsed.

The key components of the intense source section are the rotating target and the ion source. The rotating target is proposed, with respect of the heat dissipation and the removal of 3 kW/cm², in continuous operation. A rotation speed up to 1100 rpm is considered. The ion source should deliver about 0.5 kW of extracted D⁺ ion beam power. A duoplasmatron source with an electrostatic beam focusing system has been selected.

Low current sections of the neutron source may operate with a higher frequency ion source as well. The dc section for maximum yields around 10¹⁰ n/s is designed with special regard to beam monitoring. The fast pulsed section should produce up to 1 ns a compressible pulsed D⁺ ion beam on a target spot with a 5 MHz repetition rate.

The report includes information about other components of the neutron source as a high voltage power supply, a vacuum system, beam transport, a diagnostic and control system and basic information about neutron source cells and radiation protection.

МНОГОЦЕЛЕВОЙ ИНТЕНСИВНЫЙ ИСТОЧНИК НЕЙТРОНОВ С ЭНЕРГИЕЙ 14 МэВ В БРАТИСЛАВЕ – КОНЦЕПЦИЯ ПРОЕКТА

В статье даются сведения о текущем состоянии проекта многоцелевого интенсивного источника нейтронов с энергией 14 МэВ, конструируемого на базе пучка ионов D⁺ и металлической тритидевой мишени. Это прежде всего электростатический ускоритель с воздушной изоляцией, способный ускорять пучок ионов дейтерия с максимальной интенсивностью 10 мА до энергии 300 кэВ. Предполагается, что

* Contribution to the IInd International Symposium on Neutron Induced Reactions, SMOLENICE, Czechoslovakia, June 25–29th, 1979.

** Institute of Physics, Slov. Acad. Sci., Dúbravská cesta, CS-899 30 BRATISLAVA.

*** Technical University, DDR — 8027 DRESDEN.

с помощью такого пучка и участка падения пучка площадью 1 cm^2 можно будет достигнуть характеристического выхода нейтронов $10^{12} \text{ n} \cdot \text{cm}^{-2}$ и полезное время жизни мишени будет около 10 часов. Разные требования позволенной будут удовлетворять три типа пучков: интенсивный, слабощелочный прямого тока и слабощелочный быстропульсирующий.

Основными составными частями интенсивного источника являются вращающаяся мишень и ионный источник. Предполагается, что в континуальном режиме работы на вращающейся мишени будет рассеиваться и отдаваться тепло величиной $3 \text{ кВт} \cdot \text{см}^{-2}$. Скорость вращения будет достигать 1100 оборотов в минуту. Источник ионов должен расходовать около $0,5 \text{ кВт}$ мощности пучка экстрагированных ионов D^+ . В установке использован источник типа дуоплазмотрона с электростатической фокусировкой пучка.

Слабощелочные секции источника нейтронов могут работать с таким же успехом с высокочастотным источником ионов. Секция прямого тока для максимальных выходов около $10^{10} \text{ n} \cdot \text{cm}^{-2}$ конструируется с учетом особенностей управления пучком. Быстропульсирующая секция должна производить пульсирующий пучок ионов D^+ вплоть до 1 нс , который будет падать на участок мишени с частотой повторения 5 МГц . В статье имеется также информация о других частях источника нейтронов также, как источник питания, вакуумная система, транспорт пучка, система контроля, включая основную информацию об размещении источника нейтронов в отдельных местах лаборатории и радиационной защите.

1. ВВЕДЕНИЕ

Интерес в 14 MeV нейтронах has been greatly stimulated in recent years by two important applications — material damage studies of controlled fusion reactors and neutron radiotherapy. Neutron source requirements for material damage studies have been reviewed by several authors [1—3]. In general, a neutron flux density of $10^{13} \text{ n/cm}^2 \text{ s}$ or greater is needed at the location of the irradiated samples. For radiotherapy a total yield of 10^{12} — 10^{13} n/s will be sufficient, giving a dose rate of 6 Gy/h about 80 cm away from the source concepts for intense 14 MeV neutron generation in which the above mentioned requirements are considered have been developed so far. Some of them already have been in routine operation for a long time [4—6]. At the IPSAS, a study group has been formed to analyse first the technical means for the development of a very intense neutron generator and secondly to study in more detail its possibilities for nuclear fundamental as well as applied research. The results were partly reported elsewhere [7—8]. An important conclusion was that the development should any case proceed via the intermediate step. Such a goal could be attained with a reasonable chance in due course, given enough possibilities for an advanced nuclear physics research. Further, it seemed justified to concentrate simultaneously mainly on requirements of neutron spectroscopy, solid state physics and accelerator technology.

The program of the IPSAS to develop intense, low current dc and low current fast pulsed sources of 14 MeV neutrons is based upon the extrapolation of the technology of the D^+ ion beam, the tritiated metal target system [9—11] and

experience obtained by the authors of the project and other co-workers at routine operation of two 150 keV Cockcroft-Walton accelerators [12].

The intense section of the neutron source should be capable to produce a 10 mA separated D^+ ion beam. The beam generated in an ion source is accelerated to an energy of 300 keV by an electrostatic air insulated acceleration tube and further transported to a rotation target chamber. With such a beam and a fresh target a neutron yield of 10^{12} n/s , for a beam spot of 1 cm^2 and a useful target life time around 10 h can be expected. The rotating target is proposed with respect to heat dissipation and the removal of 3 kW/cm^2 in continuous operation. A rotation speed up to 1100 rpm is considered. A duoplasmatron source with an electrostatic beam focusing system has been selected for delivering about $0,5 \text{ kW}$ (50 kV , 10 mA) of extracted D^+ ion beam power. The selection will be used for precise measurement of small reaction cross sections with the aim to obtain information about clusterization in nuclei as well as to study extremely weak reactions of astrophysical importance.

The low current dc section has been designed to produce a neutron yield of up to 10^{10} n/s . A commercial tritium — loaded target on a copper or molybdenum backing has been considered. At a D^+ ion beam current of $0,1 \text{ mA}$ of 300 keV an energy bombarding a $4,5 \text{ cm}$ diameter target disk, a beam spot of the size of $0,36 \text{ cm}^2$ and a useful target lifetime of about 5 h are expected. The section may operate with a high frequency ion source as well and replaces our old neutron generator used so far. It will enable us in future to continue in nuclear reaction cross section studies under better operation conditions. Further, it is intended to exploit the section for several application programs such as proton-induced-X-ray-analysis and protonography to meet primarily solid state demands. Also, it should serve for specific accelerator purposes.

The low current fast pulsed section will be capable to generate up to 1 ns a compressible D^+ ion beam on a target spot. Here again a commercial tritium-loaded target is considered. At a D^+ ion beam current of $0,5 \text{ mA}$ (mean current in 1 ns pulse) of 300 keV energy, a spot size of $0,1 \text{ cm}^2$ and a useful target lifetime of about 50 h are expected. The section may also operate with a high frequency ion source under continuous conditions, as well as the dc section. The repetition rate of the system will be 5 MHz . The section will be used for time-of-flight neutron spectroscopy and for studies of the structure and decay modes of highly excited nuclear states by means of a multidetector and correlation setup.

II. НЕЙТРОН ИСТОЧНИК

The scheme of the neutron source is in Fig. 1. Deuterons are extracted from the plasma of a duoplasmatron or a high frequency ion source. In the case of the

duoplasmatron ion source the beam is passed to a double focusing magnet which is placed directly in the high voltage terminal. This magnet is designed for the D^+ separation from molecular ions, allowing the acceleration tube and the beam transport system to be optimized for a single species. Also a sufficient conductance path is provided from the ion sources to the acceleration tube and a 30 l/s (air) auxiliary ion pump is used to pump the ion source. The Einzel lens is included to meet desirable focal properties of the acceleration tube. An adjustable slit is suitably placed at the focal plane of the 20° magnet. Sparking problems should be reduced by use of this low energy beam transport system. The unwanted molecular ions, the energetic neutral fraction and other unneeded gases produced by the ion source should be removed from the high field region of the accelerator column. Details of this design have not been under construction, yet. The beam will be directly conducted to the acceleration tube if the high frequency ion source is used. After acceleration, the beam will be further passed either to the rotation target section or to low current sections. Specifications of the various subsystems of the neutron source are discussed in detail in the following subsections.

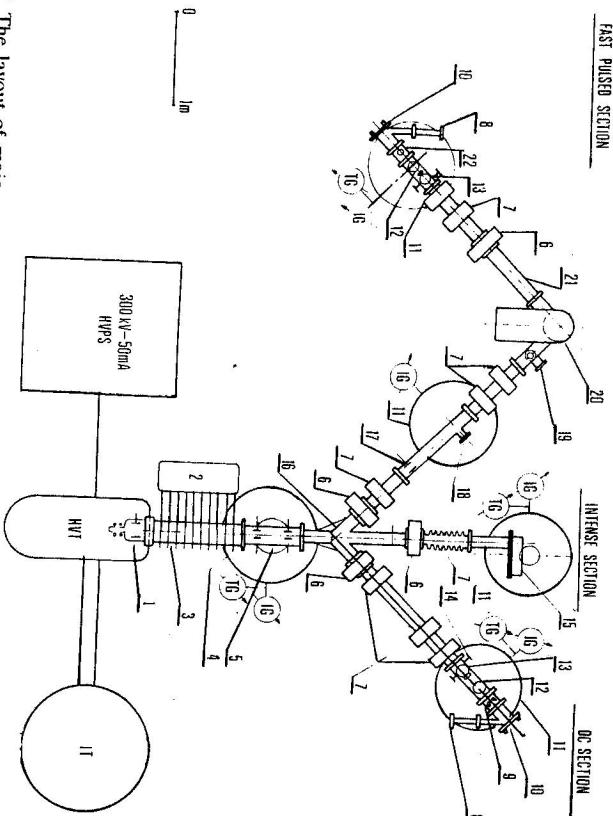

Fig. 1 The layout of major components of the FPSAS neutron source: 1 - ion source, 2 - column resistors, 3 - accelerator tube, 4 - main vacuum system, 5 - beam corrector, 6 - gate valve, 7 - quadrupole lens, 8 - α monitor, 9 - static beam monitor, 10 - target chamber, 11 - auxiliary vacuum system, 12 - water cooled target, 13 - water cooled slit, 14 - beam profile monitor, 15 - rotating target, 16 - analysing-switching magnet, 17 - chopper, 18 - slit, 19 - diaphragm, 20 - 90° magnet, 21 - bunching system, 22 - pick-up system.

II. 1. High voltage power supply and terminal

The contract for the major high voltage components of the neutron source has been made with TUR Dresden (N. E. Transformator and Roentgen Plant). The scheme of this supply together with a capacitor battery, water resistor and stabilizer is shown in Fig. 2. The basic characteristics (300 kV, 50 mA) are obtained through double wave rectifying capacitor stands and a stabilizer system after increasing the voltage on the high voltage transformer. The assembling of the rectifying part is composed of Se diodes. It has been designed in such a way as to allow an easy diodes removal or replacement in the case of failure. The supply is constructed with respect to a long operation either at 40 mA/20 °C or 30 mA/35 °C. The high voltage will be regulated by a motor-operated regulation transformer which is connected to distribution mains through a mains stabilizer. The ripple factor of the supply is 2.5 %. The capacitor battery which consists of 14 capacitors (1.5 μ F, 30 kV) is added in order to obtain better parameters of the system. We shall be able to reduce the ripple factor to 1 % by use of such a stand. Moreover, the whole system will be stabilized. Tests of a similar stabilizer [13—14] showed a long term stability of 0.15 % in 6 h caused mainly by thermal instabilities in the reference voltage system. Thus energy uncertainty of the D^+ ion beam will be better than 0.5 keV. The high voltage power supply is separated from a neutron source terminal. They are connected with a high voltage cable. Suitable cable terminals are

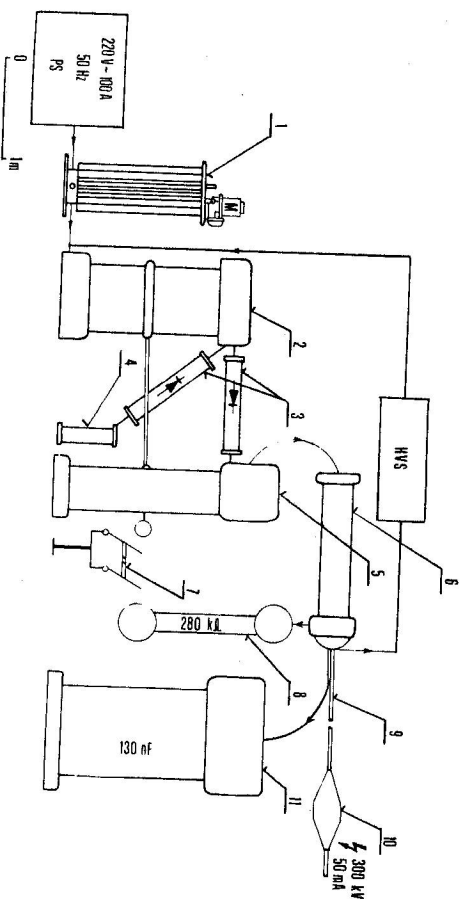

Fig. 2 The scheme of the high voltage power supply: 1 - regulating transformer REO gs 16/380, 2 - high voltage transformer PEO (IZ) 25/300/C, 3 - Se rectifier, 4 - resistor, 5 - multiplier capacitors, 6 - protective resistor, 7 - electro-hydraulic discharger, 8 - water resistor, 9 - high voltage cable, 10 - cable terminal, 11 - capacitor battery.

designed to prevent a breakdown between a polyethylene isolation and lead cable covering [15—16].

A high voltage terminal of an approximately 1.6 m² surface and 0.6 m high will contain the ion source and the associated equipment. Power will be supplied by a 10 kV/A isolation transformer.

The high voltage power supply will be connected to the terminal through an 1 k Ω damping resistor to decrease the energy available in the sparkdown. An air-insulated crowbar switch may be added. This sparkgap system can quickly short the terminal to ground and protect the acceleration column from spark damage.

II. 2. Ion sources and acceleration tube

The ion source selected for operation in this neutron source will be a modification of the duoplasmatron source developed in Vakutronik Dresden (N. E. Vacuum Electronic Plant) [17]. Its scheme is shown in Fig. 3. This type of the ion source has been tested in routine maintenance in continuous operation at 1 A and 2 A arc currents. The original version of the ion source is capable of 23 mA dc at 55 kV with a beam divergence less than 0.6 rad [18—19]. There are considered

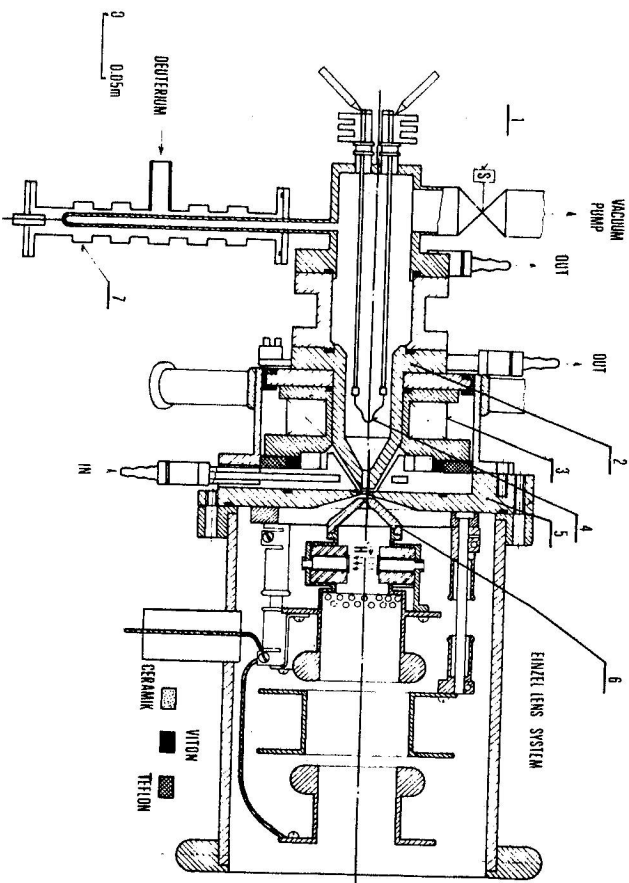

Fig. 3. Duoplasmatron ion source scheme. 1 — solenoid valve, 2 — intermediate electrode, 3 — coil, 4 — cathode, 5 — anode, 6 — extraction electrode, 7 — Pd valve.

changes of the cathode current supply leads, the cathode, the anode Mo mask on the plasma side of the extraction electrode and all gaskets for the 10 mA target current applications.

The acceleration column assembly together with the high frequency ion source is unique also for the production of the D⁺ ion beam. The point is in an electrodeless plasma formation. The 27 MHz radio-frequency power of 250 W is coupled to a gas with a pressure of 1 Pa contained in a glass container. This causes an extension of the high energy tail of the thermal energy distribution of the few initiating electrons. The ionization threshold of the gas is then increased and secondary electrons are formed and multiplied until the plasma gets so dense that the radiofrequency power is screened off and a saturation situation is achieved. The ions are extracted through a rather narrow channel by biasing the plasma relative to the outlet. The source is designed to obtain a 1 mA D⁺ ion beam in the target spot about a 6 kV extraction voltage with a beam divergence of less than 0.3 rad [19].

The acceleration tube [20—21] is composed of base flanges fitted on the main body of the neutron source, with eleven high voltage porcelain rings of a 14.8 cm inside diameter and 6.3 cm length. Between the rings there are inserted aluminum electrodes. The whole system is glued together with polyvinylacetate foils. A lead

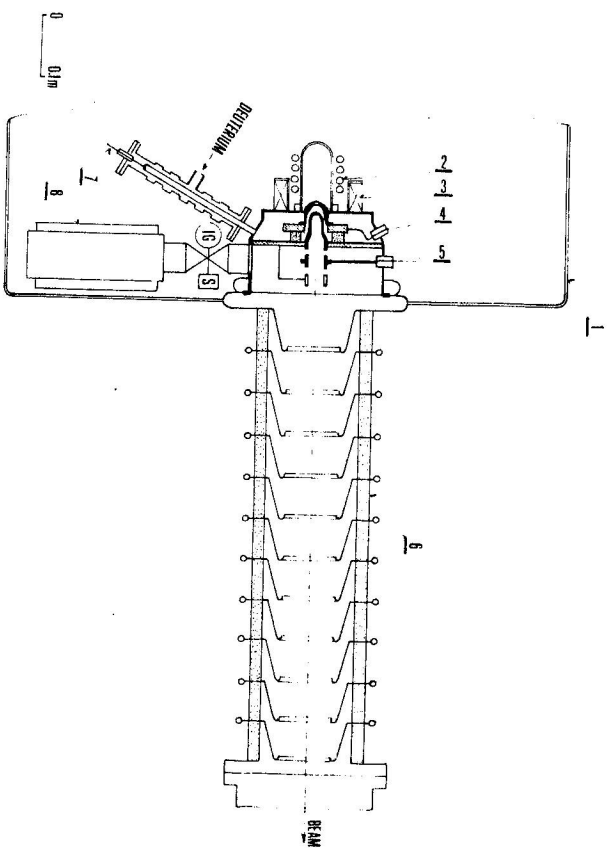

Fig. 4. High frequency ion source and acceleration column assembly. 1 — 300 kV equipment dome, 2 — high frequency coil, 3 — Helmholtz coil, 4 — extraction electrode, 5 — focusing electrode, 6 — acceleration tube.

seal is fitted between the polyvinylacetate layer and the inner part of the tube to prevent any degassing of glue. A uniform gradient below 5 kV/cm is maintained in air on the outside of the tube. The acceleration tube has been made in the Institute of Nuclear Research, Warsaw. The scheme of the high frequency ion source together of the acceleration column is shown in Fig. 4.

A multiple series resistor block (30 M Ω , 30 kV) in oil with a current draw of 1 mA will be used to grade the acceleration column.

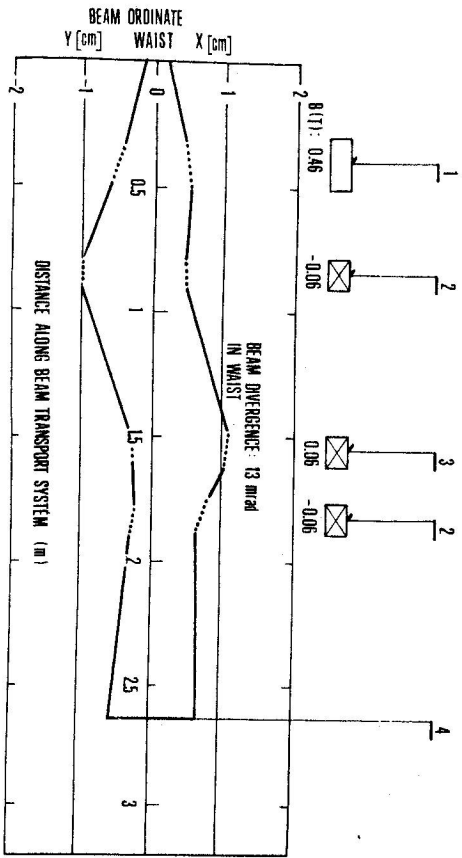

Fig. 5. Envelope for a trial beam transport system in a low current dc section. 1 - analysing - switching magnet, 2 - quadrupole lens, 3 - target.

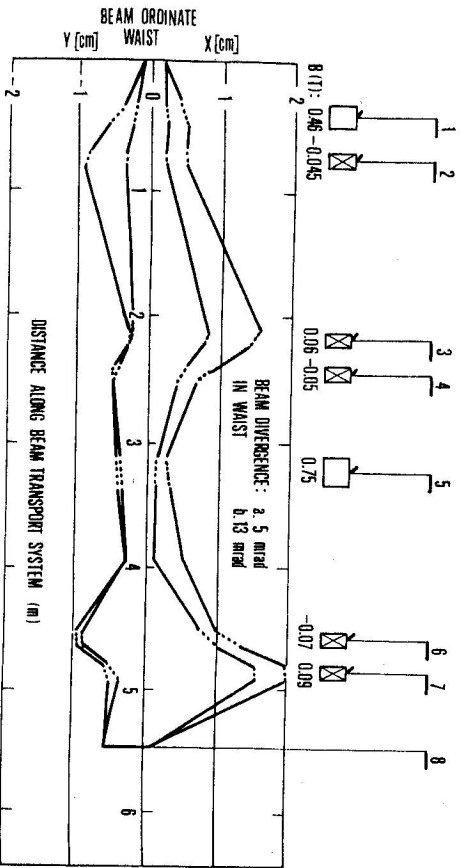

Fig. 6. Envelope for a trial beam transport system in a low current pulsed section. 1 - analysing - switching magnet, 2 - quadrupole lens, 3 - 90° magnet, 4 - target.

The optical properties of the tube have been calculated without considering the effect of space charge. It has been determined that a beam waist at the point near the switching magnet will be created by use of the focusing Einzel lens system.

II. 3. Beam transport

The beam transport system should be able to pass the beam from the accelerator and create the desired spot size on the target. A major uncertainty in the design of such a system is the influence of the space charge on the beam transport and a degree of neutralization of the space charge in beam drifts. This uncertainty affects both the strength and the number of lenses required as well as the size or desirability of waists or crossovers in the beam.

Envelope calculations for the beam transport in the low current sections for a two-beam divergence in the waist are shown in Fig. 5 and Fig. 6. It has been assumed that the beam is fully neutralized in all high energy drift regions and denaturalized in the magnets and quadrupole lenses. By use of three 5 cm aperture quadrupole lenses placed at 0.8 m, 1.4 m and 1.8 m along the beam line in the dc section, a beam spot with ordinates of 0.6×0.6 cm² can be produced with the analysing magnet field of 0.46 T and a maximum field on the second elements below 0.06 T.

Two magnets are designed to draw the beam at the target chamber of the pulsed section. The beam is driven to a second experimental neutron source cell. By use of five 5 cm aperture quadrupole lenses placed at 0.7 m, 2.1 m, 2.4 m, 4.6 m and 4.8 m along the beam line, a beam spot with ordinates of 0.06×0.6 cm² can be achieved at the beam divergence of a 5 mrad in the waist. We have considered the 90° magnet field of 0.75 T. The maximum field on the quadrupole lenses is below 0.09 T.

Envelope calculations for the beam transport in the intense section have not been in process of completion, yet.

II. 4. Target system

In order to produce the intense 14 MeV neutrons a rotating target is being considered in the intense section. It has been designed to use 16 titanium tritide targets manufactured in the USSR [22]. The kinds of the targets are for us the most available. The main data of the rotating target device and parameters of the target elements are given in Tab. 1 and Tab. 2. The target lifetime were calculated from data presented in ref. [23—24]. A detailed scheme of the rotation target system is shown in Fig. 7. The target elements are located in a rotation disk 11. The layout of the targets through the disk „periphery“ is seen in Fig. 8. The „ring“ shaped target $D_{int} = 19$ cm, $D_{ext} = 28$ cm contains totally 15 TBq tritium. At the target operation,

Table 1
IPSAS neutron source parameters

Intense section	Current DC	Low sections pulsed
Beam energy (keV)	300	300
HV supply current (mA)	50	50
Target current (mA)	5–30	0.002
Spot size (cm ²)	1	0.1
Target diameter (cm)	30	4.5
Heat dissipation (kW/cm ²)	1.5–9	10 ⁻²
Target speed (rpm)	35–1110	—
Neutron yield (n/s)	5×10^{11} – 3×10^{12}	10^{10}
Maximum flux (n/cm ² s)	4×10^{10} – 2×10^{11}	8×10^8
Sample target distance (cm)	0.7	0.9
Target lifetime (h)	10	5
Beam compression from-to (ns)	—	—
Repetition rate (MHz)	—	46–1 5

Table 2
Specification of tritium target elements

Target: Ti/T atomic ratio	Cu-Ti (Mo/Ti): 1.5
Diameter (cm)	4.5
Effective diameter (cm)	4
Thickness of target backing (cm)	0.03
Thickness of TiT layer (μm)	2–5
Concentration of tritium (GB_q/cm^3)	60

the target is cooled by water which is driven in the centre of the rotating target assembly to a cavity from where it is further delivered to eight 0.5 cm diameter channels. Two targets are connected to one channel. To cool the target to a suitable temperature with respect to the tritium desorption rate, it is necessary to supply the channels by a sufficient amount of cooling water. Our design assumes that water consumption would not be higher than 70 l/min which corresponds to the minimum water velocity in channels of 1.5 m/s.

The rotor is moved in a vacuum of 10^{-3} – 10^{-4} Pa. It is separated from the high vacuum by three special „O“ rings sealings, which are fixed by a support. Two simmerings separate the vacuum chamber from the outside environment. The cavity placed between the rings and the simmerings is pumped by a differential pumping system. It involves a mechanical rotary pump and a forline trap. The target chamber is pumped by an EGZ 100 ion pump. The rotor is further carried

in two high precision ball bearings which allow only a small free vibration. We expect that the bearings will be suitable for target operations at any speed up to 1100 rpm although the necessary target revolution rate for the heat dissipation of 1.5 kW/cm² is about 35 rpm [25].

Special attention has also been paid to studies required to simulate the behaviour of a titanium tritide target at the operation by the D⁺ ion beam. Heat

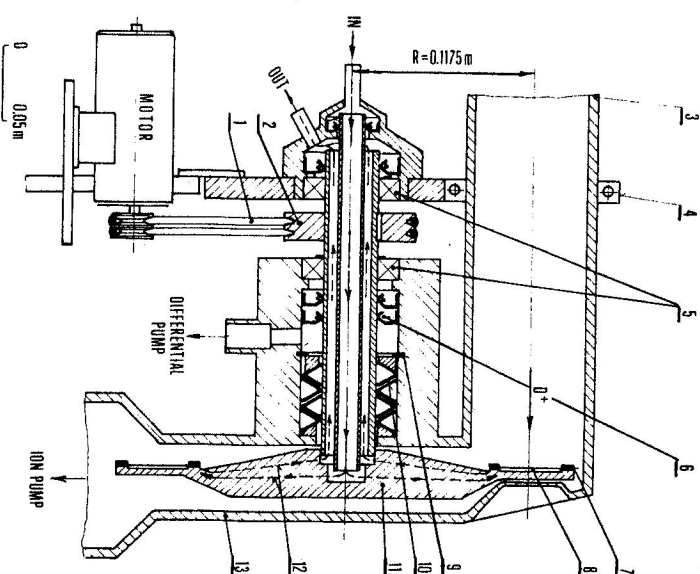

Fig. 7. Detailed scheme of the rotation target. 1 – V belt, 2 – pulley, 3 – beam tube, 4 – isolation support, 5 – bearings, 6 – simmerings, 7 – ring, 8 – target, 9 – support, 10 – sealing “rings”, 11 – isolation support, 12 – water channels, 13 – stator.

dissipation and heat transfer problems have been investigated. It was assumed that the heat absorbed into the surface layer of the target is only caused by the stopping of the incoming deuterons. It is quicker transferred to the backing of the target than it is accumulated into the surface layer. The heat transfer problem was subdivided into three distinct phenomena, namely conduction, convection and radiation. It was found that the heat transferred by conduction parallel to the deuteron beam axis plays a predominant role in the heat balance. Therefore only conduction was considered.

Temperature changes in the surface layer and backing of the target are given by the linear differential equation for heat conduction. We have only calculated the changes in the backing of the target which is thermally isolated from the side and has a good thermal contact with the cooling water along the back. The backing is exposed to a pulsed deuteron beam with a rate q (q is the rate of the heat input per unit time and unit surface). A similar task has been solved in ref. [26—27]. The results are also summarized in ref. [25].

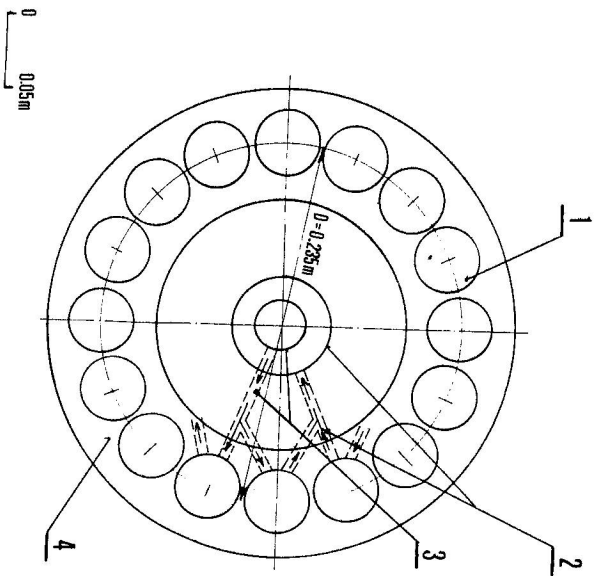

Fig. 8. The layout of the 45 mm diameter rotation disk "periphery". 1 - target segment, 2 - water outlets, 3 - water inlets, 4 - clamping ring.

The calculated curves for two sets of values for the rates q , n and the constant temperature difference $T_0 - T_a$ are shown in Fig. 9 (n is the revolution rate, T_0 the temperature of the target backing at the back and T_a the temperature of the cooling water). The curves characterize the temperature distribution during and after D^+ ion beam actions in a target layer between TIT and the backing (Fig. 9). The curves a, b start at the beginning of every period at 60 °C and 35 °C, respectively. This also holds for every end of the period. It can also be seen that the temperature of the layer does not exceed about 115 °C both for the rates 1.5 kW/cm², 35 rpm and 9 kW/cm², 1100 rpm at $T_0 - T_a = 2.5$ °C. The time dependent temperature calculations have been done for an equilibrium loading

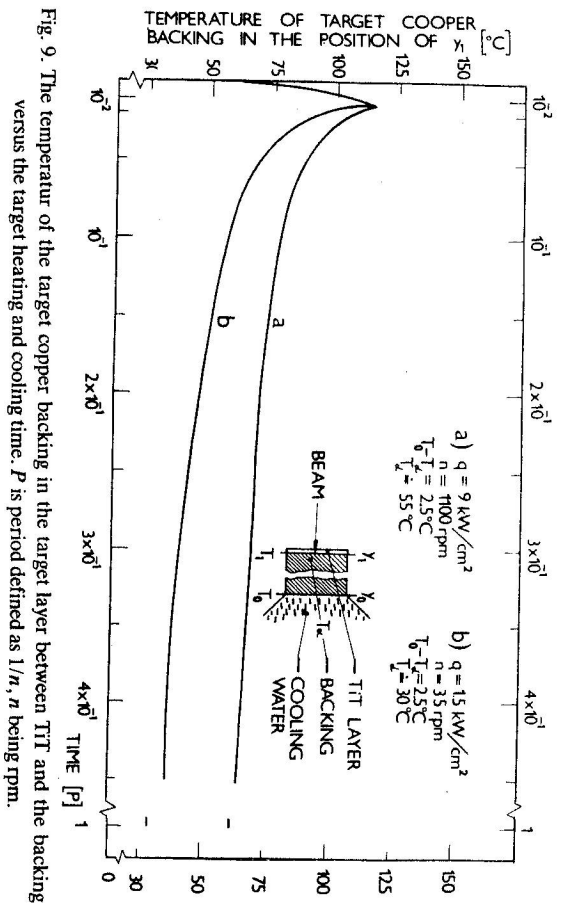

Fig. 9. The temperature of the target copper backing in the target layer between TIT and the backing versus the target heating and cooling time. P is period defined as $1/n$, n being rpm.

cycle. The cycle sets in after about 20 and 500 revolutions for the rates 1.5 kW/cm², 35 rpm and 9 kW/cm², 1100 rpm, respectively [25]. The low current target chambers will use neutron fixed targets for the production of 14 MeV. Water is also used as a coolant and is driven to a channel placed near the target periphery. Such a target can be loaded up to 300 W/cm² without considering the tritium losses [23].

II. 5. Pumping

One main and four auxiliary vacuum system have been considered for pumping. The system is constructed from stainless steel. Conflat flanges and copper gasket seal will be used throughout the high vacuum side. In solenoid valves VITON rings will be used and in the target chambers In(Al) wire rings. The high vacuum part is entirely bakeable.

The schema of the main pumping unit is shown in Fig. 10. A 2000 l/s diffusion pump together with a baffle, a liquid-nitrogen trap, two sorption Zeolite pumps, a foreline trap and a rotation pump will be used. The effective pumping speed of the pump in the region of the beam source corrector is 250 l/s for air at a pressure 10^{-2} Pa. The effective pumping speed of the pump in the region of the ion source is about 60 l/s at a pressure 2×10^{-3} Pa. This pumping speed together with the speed of the auxiliary ion pump are also sufficient to pump the duoplasmatron ion source in the generation of a 20 mA deuteron beam at a pressure 2×10^{-3} Pa. As sorption pumps the EGS 500 type produced in HV Dresden (N.E. High Vacuum

Plant) have been considered [28]. The pumping speed of the pump is 40 l/s when zeolite 5A is used. The foreline trap has also been designed with an expected conductivity higher than 10 l/s. Zeolite 13X is used for pumping oil vapours, which are desorbed from the rotation pump. There is only one rotation pump considered for repumping the neutron source or the target chambers from atmospheric pressure to 10 Pa. The diffusion pump is obviously pumping in connection with the

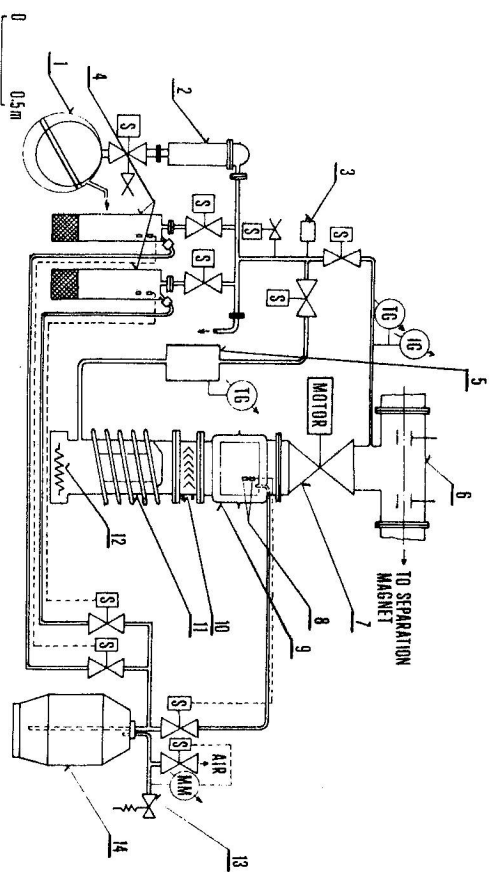

Fig. 10. The scheme of the neutron source main pumping unit. 1 – rotary pump, 2 – adsorption trap, 3 – vacuum relay, 4 – sorption pumps, 5 – vacuum reservoir, 6 – beam corrector, 7 – plate valve, 8 – LN₂ level sensing elements, 9 – trap, 10 – baffle, 11 – diffusion pump, 12 – pump heater, 13 – safety valve, 14 – LN₂ reservoir and MM membrane manometer.

sorption pumps. Dynamic pressures lower than 10^{-4} Pa without carbon components are expected in the region of the beam source corrector and the target chambers. The pressure inside the system is measured by a thermocouple and ionization gauges. The contract for such a pumping unit has been made with Tesla Rožňov (N.E. High Vacuum Division, Opočno, CSSR).

An automatic liquid-nitrogen level controller and transfer system for the liquid-nitrogen trap and sorption pumps will be used [29–30]. A liquid-nitrogen consumption of about 2 l/h is expected.

The auxiliary vacuum system (Fig. 1) will be used for jumping the pulsed beam line and all target chambers. They are based on the EGZ 100 type ion pumps produced in HV Dresden. The pumping speed of the pump is 100 l/s for air at the pressure of 10^{-2} Pa.

II.6. Diagnostic and control systems

To operate neutron source in a reproducible fashion for experimental work, diagnostic devices are required for all beam lines.

It has been considered to make exit ports for the neutral, D₂⁺ and D₃⁺ beam components extracted from the duoplasmatron ion source in the vacuum ‘‘chamber’’ of the 20° double focusing magnet in the high voltage terminal. Experiments will be made to determine the emittance of the D⁺ ion beam. The suitable data will be transmitted from the high voltage terminal to the ground. Simpler systems are considered for beam scanning in the beam line: noninteractive beam scanners will probably be used for measuring the high intensity beam profile. Beam profile measurement at one location along the intense beam line should provide information about the target spot size.

Dynamic beam monitors [31] and beam catching targets [32] have been designed for the low current target chambers.

Measurement of neutron yields may be carried out with proton recoil counters in the intense section and with monitoring silicone detectors in the low current sections.

Since the neutron source will operate at one energy and produce a single ion species, the control of the neutron source and the beam transport system will be simple. The computer control of the neutron source does not offer essential operational advantages. There is, however, a certain space for control by the microprocessor system. The controls of most parts will be hardwired in the neutron source. An optoelectronic channel for the control of power supplies, etc. in the high voltage terminal has been designed. Analog information from the terminal to the ground will be transformed to digital form and transmitted via a multiplexed fiber optic system.

II.7 Nanosecond pulsing system

For an increasing number of experiments [33] it is necessary to have very short (1 ns) pulses of 14 MeV neutrons with a high pulse power. Such pulses will be generated in a low current pulsed section in two steps. In the first step, ion pulses of a length of 46 ns will be produced in a chopper. In the second step these pulses are compressed to the required length in a bunching system [34–35]. The main data of this system are given in Tab. 1. The analysed beam will be deflected by a pair of plates and the unwanted part of the beam will be stopped by a chopper slit. The 46 ns pulsed beam is further driven to a buncher through a 90° bending magnet. The chopper is separated from the target room of the pulsed section to prevent a D-d neutron background. The buncher has been designed with three bunching slits. A compression ratio $\tau/\Delta\tau = 0.02$ at the buncher frequency 10 MHz is expected ($\tau = 1$ ns, $\Delta\tau = 46$ ns).

III. NEUTRON SOURCE CELLS

The laboratory with the neutron source must provide shielding from both prompt and induced radiation. All irradiation of materials and handling of activated samples must be carried out in a shielded room separated from the control and light laboratory areas.

III.1. Cells and ventilation

The IPSAS neutron source is mounted in four rooms: the power supply room, the accelerator room with the intense and the low current dc beam lines, the low current pulsed beam line room and the operating room. A floor plan for the facility is shown in Fig. 11. The total area of the neutron source rooms is approximately 100 m². Suitable doors have been designed to ensure biological protection. The rooms are equipped with a ventilation system capable to exchange air completely four times per hour under s. c. Tritium outgassed from the targets during the

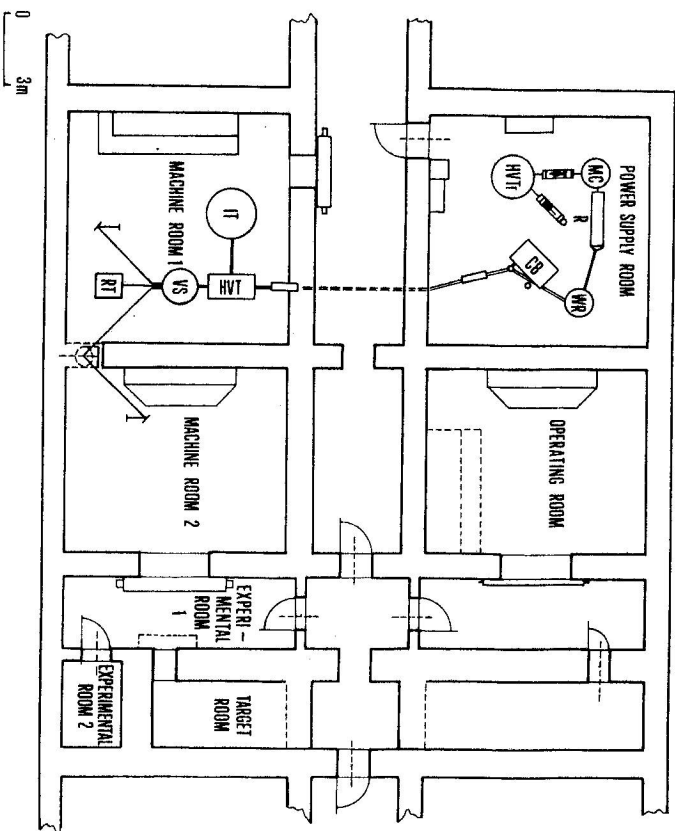

Fig. 11. The floor plan of the multipurpose neutron source. HVT - high voltage transformer, MC - multiplier capacitor, R - resistor, WR - water resistor, CB - capacitor battery, HVT - high voltage terminal, VS - vacuum system, IT - isolation transformer, RT - rotating target.

134

production of 14 MeV neutrons will remain within the vacuum systems, therefore no hazard of tritium contamination during operation is expected.

III.2. Shielding

Shielding of prompt radiation is provided by at least 80 cm thick concrete walls around the source. All the shielded rooms except the corridor are accessible and do not face the neutron source directly. A maximum dose rate outside the shielding of the neutron source will be less than 0.01 mGy/h [36]. The dose reduction factor of the 80 cm thick concrete wall is 5×10^{-4} . The dose rate of the target assembly and other components of the target cell immediately after shut down will be very high (approximately 20 Gy/h [6]). This level will be decreased after several hours. We expect that the target assembly can be removed and replaced after about 24 h.

IV. CONCLUSIONS

The characteristics of the multipurpose neutron source utilizing a rotation target in the intense section and fixed targets in the low current section for generating 14 MeV neutrons, the technology of critical components and the actual design characteristics have been shown. With this neutron source, together with the rotation target, it should be possible to improve significantly irradiation possibilities in the future.

REFERENCES

- [1] Hourst, J. B., Roche, M.: *Accelerator for the production of very high neutron yields of 14 MeV*. Proc. Int. Conf. on Radiation Test Facilities for the CTR Surface and Materials Program, ANL-CTR-75-9, Argonne National Laboratory, USA 1975.
- [2] Ullmaier, H., Behrish, R., Barshall, H. H.: *Nucl. Instr. and Meth.* 145 (1977), 1.
- [3] Kim, J.: *Nucl. Instr. and Meth.* 145 (1977), 9.
- [4] Cleland, M. R., Offermann, B. P.: *Nucl. Instr. and Meth.* 145 (1977), 41.
- [5] Hourst, J. B., Roche, M., Morin, J.: *Nucl. Instr. and Meth.* 145 (1977), 19.
- [6] Booth, R., Davis, J. C., Hanson, C. L., Held, J. L., Logan, C. M., Osher, J. E., Nickerson, R. A., Pohl, B. A., Schumacher, B. J.: *Nucl. Instr. and Meth.* 145 (1977), 25.
- [7] Ribanský, J., Horváth, P., Pivarč, J., Hlaváč, S., Šácha, J., Kolenič, F.: *High intense source of neutrons: Design - Concept*. Report IPSAS, Bratislava 1976. (in Slovak).
- [8] Hlaváč, S., Ribanský, J., Pivarč, J.: *Potrebnosť i voľnosť poľučenia očien intenzívnych izotopov neutronov*. Neutronová fyzika, Part 4, Moskva 1977. (Materiály 4. Vsesojuznoj konferencie po neutronovej fyzike, Kiev 1977).
- [9] Pivarč, J.: *Production and regeneration of deuterium and tritium targets*. Thesis. Bratislava 1975. (in Slovak, unpublished).
- [10] Pivarč, J.: *Atomik kozmický 18* (1976), 463.
- [11] Pivarč, J.: *Jad. energ.* 20 (1974), 378.

135

- [12] Bederka, Š.: *Jad. energ.* 24 (1978), 174.
- [13] Kliszewski, S., Lewandowski, Z.: *A simple stabilizer of high voltage supply for a fast neutron generator*. Report No. 826 (E) PL, Krakow 1973.
- [14] Izumi, I., Kokubu, M.: *Nucl. Instr. and Meth.* 28 (1964), 349.
- [15] Mikuš, Š.: *private communication* (1978).
- [16] Mashio, G.: *IEEE Trans. Power Apparatus and Systems* 93 (1974), 1535.
- [17] von Ardenne, M.: *Tabellen der Elektronenphysik, Ionenphysik und Übermikroskopie*. Band I. VEB Deutscher Verlag der Wissenschaften Berlin 1956.
- [18] Drška, L., Hulek, Z., Král, J.: *Private communication* (1970).
- [19] Witteveen, G. J.: *Nucl. Instr. and Meth.* 158 (1979), 51.
- [20] Jaskola, M.: *private communication* (1977).
- [21] Džmuraň, R.: *Construction of acceleration tube used in the 3 MeV Van de Graaf accelerator* (Report ÚJV Řež 2262-A, ČSSR 1969).
- [22] *Mišeni tritlevje (deuterijve) (Technickéjcie uslovia)*. Report TUL.1.173-71, Inst. jaderných sledovanií Ukrainskoj Akademii Nauk, Kiev 1971.
- [23] Sikema, C. P., Steendam, S. P.: *Nucl. Instr. and Meth.* 124 (1975), 161.
- [24] Pivarč, J., Král, J.: *rotating target for a 300 keV neutron generator: Design*. Bratislava 1979 (unpublished).
- [25] Pivarč, J.: *Heat diagnostic of rotating target for a 300 keV neutron generator*. Bratislava 1979 (unpublished).
- [26] Hůlek, Z.: *Čs. Čas. Fyz.* 14 (1964), 476.
- [27] Likov, A. V.: *Teorija teplovodnosti*. GITTL Moskva 1952.
- [28] *Sorption pump EGS 500* (Technical documentation, N. E. High Vacuum Dresden 1978).
- [29] Blanpain, R., Delviche, J. P., Melón, P., Prouvreur, F.: *Vacuum* 27 (1977), 617.
- [30] Sandhu, H. S., Bulicky, M. J.: *J. Vac. Sci. Technol.* 8 (1971), 424.
- [31] Duport, J. C., Jaccard, S.: *Nucl. Instr. and Meth.* 115 (1974), 233.
- [32] *Beam diagnostic instrumentation* (Technical documentation, Danfysik A/5, Jyllinge, Roskilde, Denmark 1977).
- [33] Gurtovoji, M. E., Lešenko, B. E., Strižak, V. I.: *Voprosy fiziki bystrych neitronov*. (Izd. Kievsogo Universiteta, Kiev 1973).
- [34] Hannappel, L., Schneider, H.: *Kerntechnik* 17 (1975), 235.
- [35] Herring, A.: *An ns pulsation system for a 150 keV neutron generator: Design*. Degreework IPSAS Bratislava 1977.
- [36] *Law Collection*. Part 20. Ministry of Health of the Slovak Socialist Republic, No 65, Bratislava 1972.

Received August 22nd, 1979